



MANUAL DE MONTAGEM
ASSEMBLY INSTRUCTIONS
INSTRUCCIONES DE MONTAJE

COD BR: BAM 08

Sumário Summary Resumen

Introdução Introduction Introducción	3
Antes de começar Before starting Antes de comenzar	4
Evite acidentes Avoid accidents Evitar accidentes	4
Dimensões e ferramentas Dimensions and tools Dimensiones y herramientas	5
Identificação das peças Identifying parts Identificación de las piezas	6
Acessórios incluídos na caixa Hardware included in box Accesorios incluidos en la caja	7
Montagem do móvel Furniture assembly Montaje del mueble	8

Introdução Introduction Introducción

Leia atentamente este manual e siga os passos indicados para que o produto não perca a garantia e também para uma perfeita montagem.

For the perfect fit, please read this manual carefully and follow indicated steps.

Lea este manual y siga los pasos para que el producto no pierda la garantía y también para el ajuste perfecto.

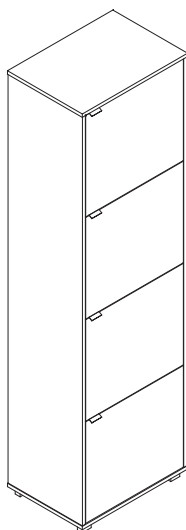

Antes de começar Before starting Antes de comenzar

Antes de começar a montagem prepare o ambiente, deixando-o completamente limpo e com bom espaço para iniciar o trabalho.

Prepare the room before starting the assembly, leaving it completely clean and the area in good condition to start the work.

Antes de comenzar el montaje preparar el ambiente, dejándolo completamente limpio y con bueno espacio para comenzar el trabajo.

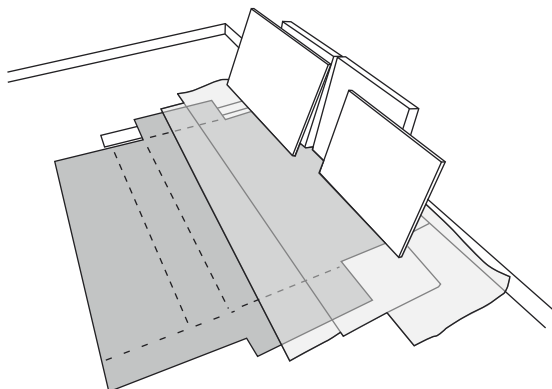

Utilize o papelão da própria embalagem para separar e apoiar as peças retiradas das caixas.

Use the cardboard of the packaging to separate and support the parts removed from the boxes.

Utilice el cartón de la embalaje para separar y apoyar las piezas desmontadas de las cajas.

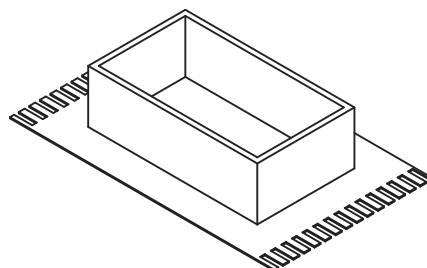

Forre a área de montagem com um cobertor ou tapete. Assim, você evita avarias nas peças durante o processo de montagem.

Cover the assembly area with a blanket or carpet to avoid damaging the parts during the assembly process.

Cubrir la zona de ensamble con una manta o alfombra. De este modo, se evitan daños en las piezas durante el proceso de montaje.



Evite acidentes Avoid accidents Prevenir accidentes

Solicitamos observar atentamente as orientações de montagem como: fixação do produto na parede, colocação de cola em locais específicos necessários, o peso suportado pelo produto, etc...

You are requested to carefully observe the assembly instructions regarding: fixing of products to the wall, adding glue where indicated, product weight limit, etc.

Pedimos que lea atentamente las instrucciones, principalmente las informaciones de fijación del producto en la pared, colocación de pegamento en local específico y necesario, el peso soportado por el producto etc...

Não escale ou se apoie no móvel.

Do not climb or lean on the furniture.

No se suba ni se apoye en el mueble.

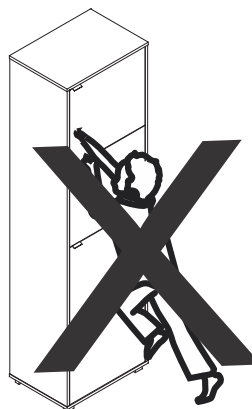

Dimensões e ferramentas
Dimensions and tools
Dimensiones y herramientas

Dimensões:

L: 535 A: 1863 P: 380 mm

Dimensions:

W: 21.06 H: 73.34 D: 14.96 inches

Dimensiones:

L: 535 A: 1863 P: 380 mm

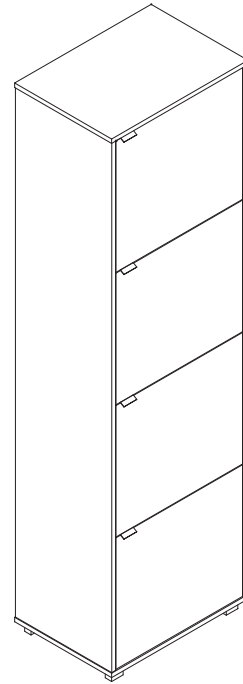

Limpeza
Cleaning
Limpieza

Pano levemente umedecido com água, seguido de pano seco, não utilizar produtos químicos ou abrasivos.
You can clean the product with slightly dampened cloth followed by a dry cloth. Do not use chemicals or abrasives.
Solamente utilizar un paño húmedo y después un paño seco, no utilice productos químicos o abrasivos.

Todas as peças do móvel foram marcadas com um número. Antes de começar a montagem, identifique as peças numeradas em relação às instruções de montagem. Uma vez concluída a montagem, os números podem ser facilmente removidos com um pano ligeiramente embebido em álcool. Use álcool apenas para remover números das peças.

All the furniture parts have been marked with a number. Before you start assembling, please identify the numbered parts in relation to the assembly instructions. Once assembly is completed, the numbers can be easily removed with a cloth slightly dampened in alcohol. Use alcohol only to remove part numbers.

Todos las piezas del mueble fueron marcadas con un número. Antes de empezar el montaje, identifique las piezas numeradas en relación con las instrucciones de montaje. Una vez que se completa el armado, los números se pueden quitar fácilmente con un paño ligeramente empapado en alcohol. Use alcohol solo para eliminar números de las piezas.

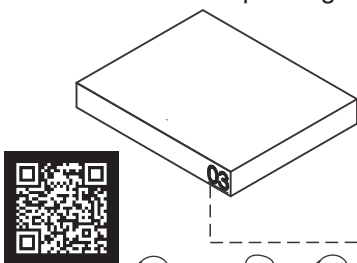

UTILIZE ALCOOL APENAS PARA REMOVER O NUMERO DAS PEÇAS
USE ALCOHOL ONLY TO REMOVE PART NUMBERS
UTILICE ALCOHOL SOLAMENTE PARA ELIMINAR EL NUMERO DE LAS PIEZAS

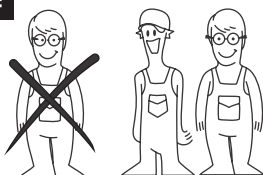

Para facilitar a montagem, utilize uma parafusadeira elétrica.
To speed assembly, use an electronic screwdriver.
Para facilitar el armado, utilice un destornillador eléctrico.

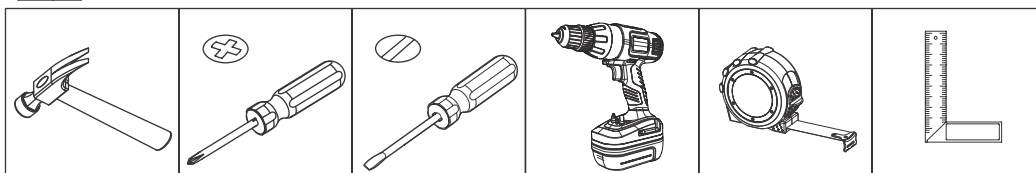

COD BR: BAM 08

PEÇA	DESCRIÇÃO	QUANT.	PART	DESCRIPTION	QTY	PIEZA	DESCRIPCIÓN	CANTIDAD
001	BASE	1	001	BASE	1	001	BASE	1
002	TAMPO	1	002	TOP	1	002	TAPA	1
003	LATERAL ESQUERDA	1	003	LEFT SIDE	1	003	LATERAL IZQUIERDA	1
004	LATERAL DIREITA	1	004	RIGHT SIDE	1	004	LATERAL DERECHA	1
005	PRATELEIRA	3	005	SHELF	3	005	REPISA	3
006	PORTA	4	006	DOOR	4	006	PUERTA	4
007	COSTA	2	007	BACK	2	007	REVÉS	2
008	PÉS	4	008	FEET	4	008	PIES	4

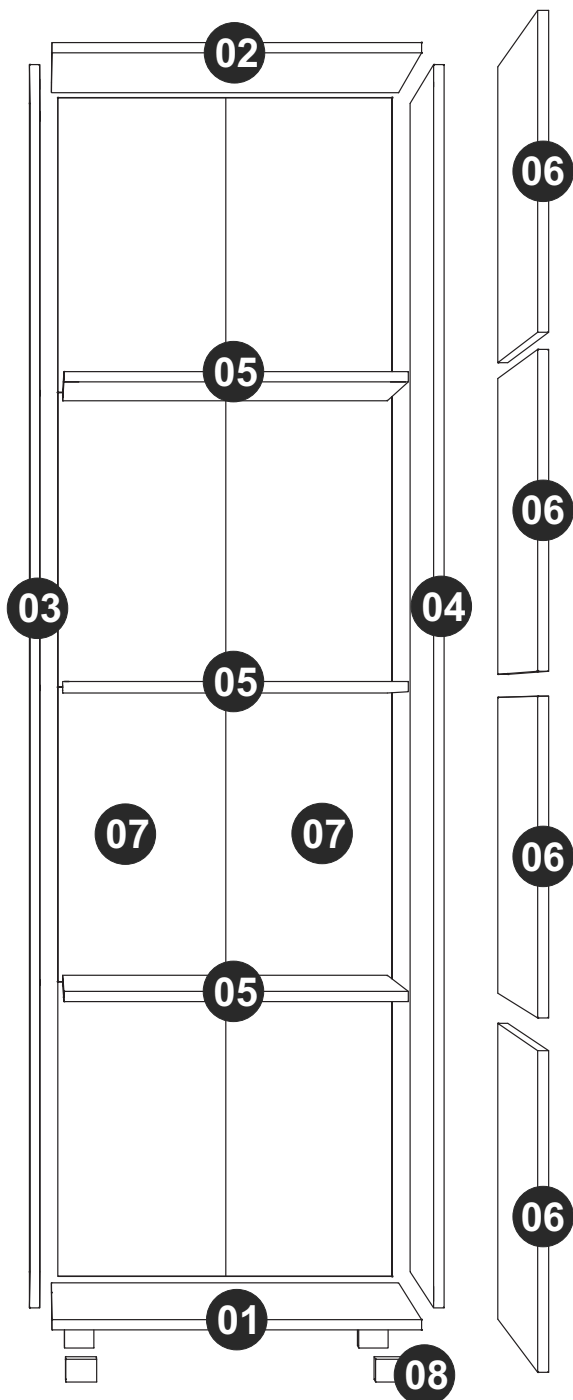

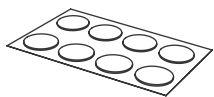

TAPA FUROS x 20
STICKER x 20
TAPAS PLÁSTICAS x 20



EF 000033 x 20
8x30



EF 000094 X 16



EF 000216 X 16



EF 000106 X 40
3,5X14 CC

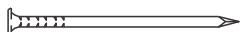

EF 000168 X 105
10X10 C/C

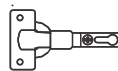

EF 000043 X 08



EF 000025 X 08



PÉS RETÂNGULARES x 4
RECTANGULAR FEET x 4
PIES RECTANGULARES x 4



EF 000132 x 04
4X50 CC

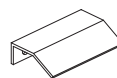

PUXADOR x 04
HANDLE x 04
MANIJA x 04



EF 000381 x 08
3X25 CC



EF 000246 x 1
5X50 CF



EF 000016 X 1

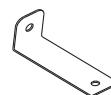

EF 000529 X 1



EF 000248 X 1
3,5X14 CP



PERFIL H x 01
PROFILE H x 01
PERFIL H x 01



GIZ x 01
CHALK x 01
TIZA x 01

Utilize para medir as ferragens.

Utilice para medir el herraje.

Use for measuring the hardware.

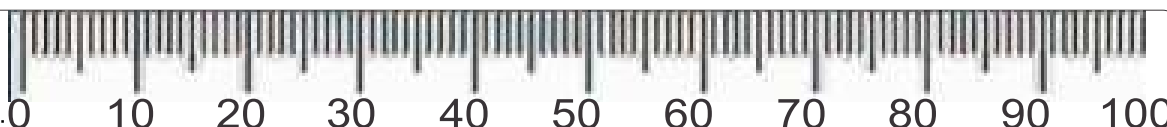

Garantia (exclusivo para o Brasil/exclusivo de Brasil/exclusive to Brazil):

A garantia dos produtos fabricados pela BRV Móveis, abrange eventuais defeitos-vícios de fabricação, no prazo estabelecido pelo código de Defesa do Consumidor, em seu artigo 26.II. o qual prevê a garantia de 90 (noventa) dias.

A = 6KG - 13.22 LB

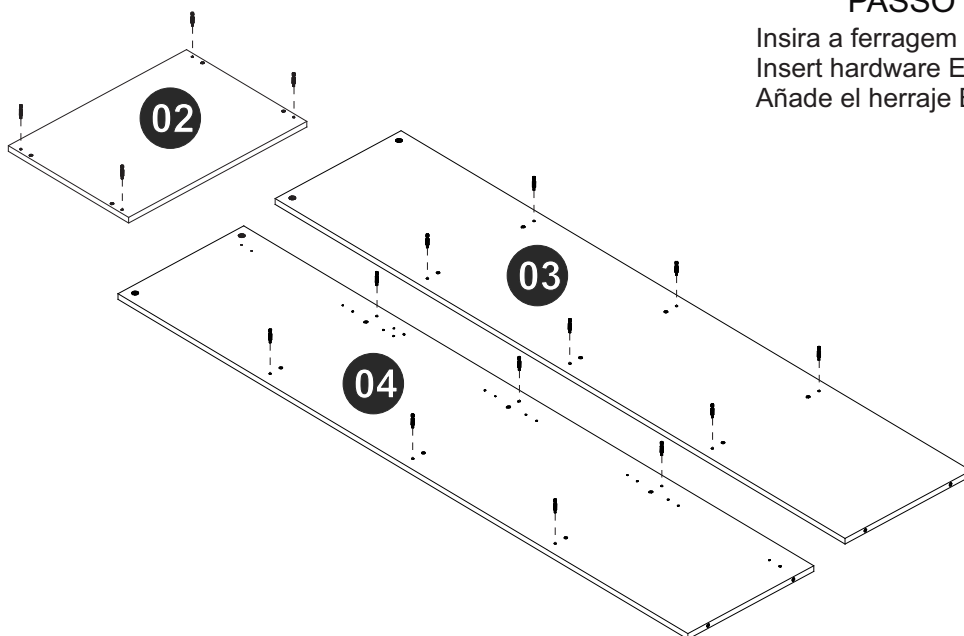
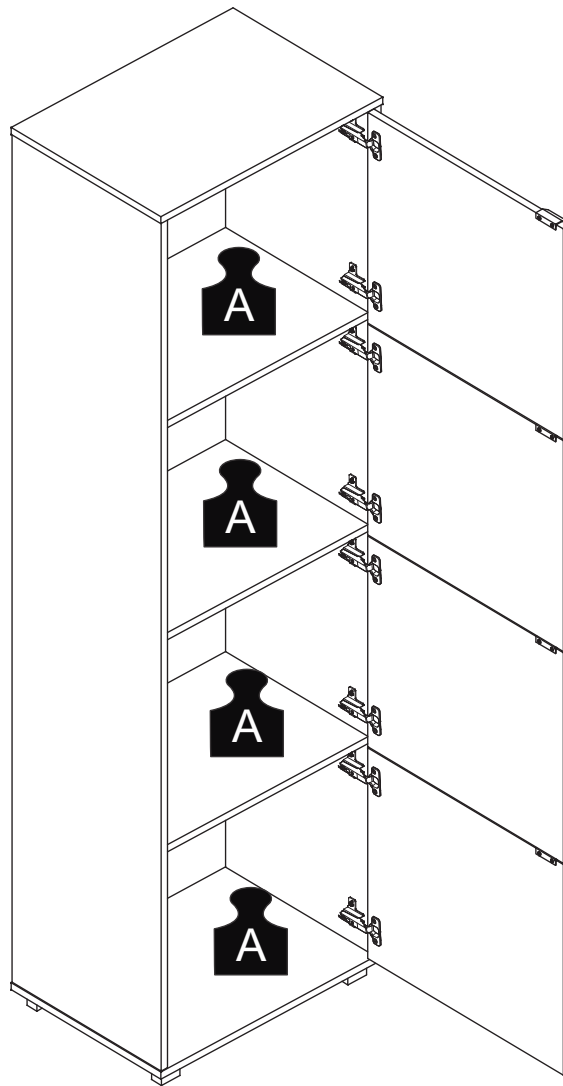

PASSO 1 / STEP 1 / PASO 1

Insira a ferragem EF 000094 nas peças 02, 03 e 04.
Insert hardware EF 000094 into pieces 02, 03 and 04.
Añade el herraje EF 000094 en las piezas 02, 03 y 04.

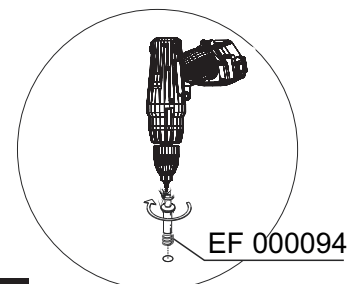

PASSO 2 / STEP 2 / PASO 2

Insira a ferragem EF 000033 nas peças 05.
Insert hardware EF 000033 into pieces 05.
Añade el herraje EF 000033 en las piezas 05.

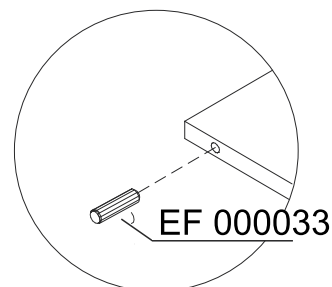
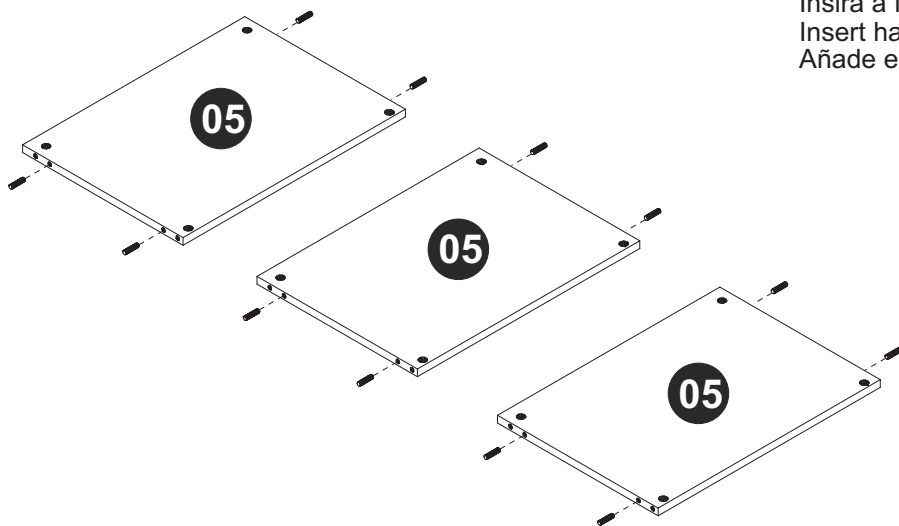

PASSO 3 / STEP 3 / PASO 3

Insira a ferragem EF 000033 nas peças 03 e 04.
Fixe a ferragem EF 000025 na peça 04 utilizando a ferragem EF 000106.
Insert hardware EF 000033 into pieces 03 e 04.
Attach hardware EF 000025 into piece 04 using hardware EF 000106.
Añade el herraje EF 000033 en las piezas 03 e 04.
Fije el herraje EF 000025 en la pieza 04 utilizando el herraje EF 000106.

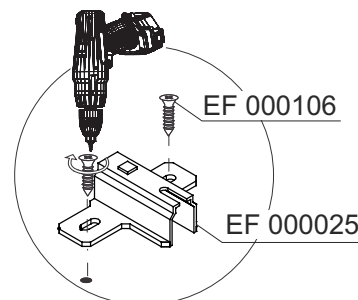
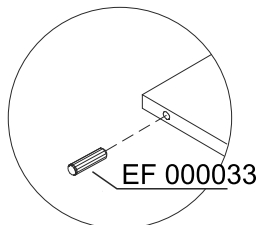
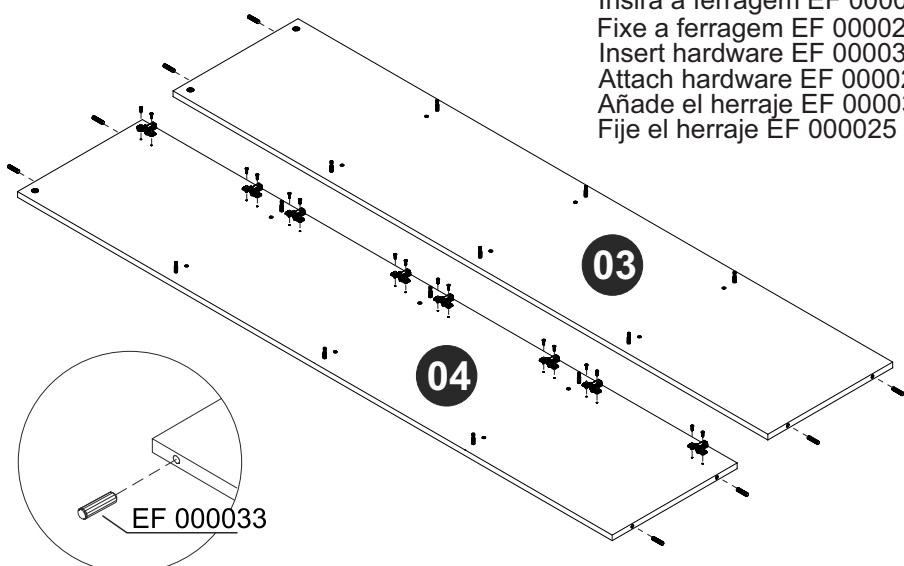

PASSO 4 / STEP 4 / PASO 4

Fixe a ferragem EF 000043 e o puxador usando a ferragem EF 000106.
Fix hardware EF 000043 and the handle using hardware EF 000106.
Fije el herraje EF 000043 y la manija utilizando el herraje EF 000106.

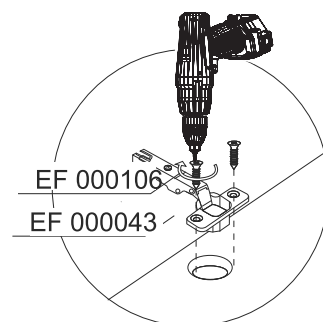
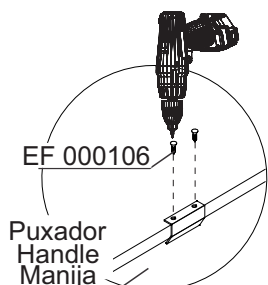
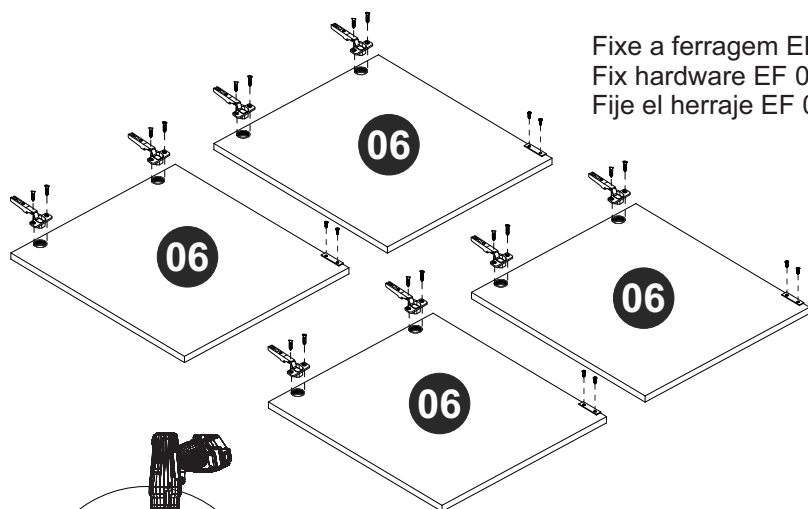

PASSO 5 / STEP 5 / PASO 5

Conecte as peças 05 na peça 03, insira a ferragem EF 000216 e gire para apertar.
Connect pieces 05 into piece 03, insert hardware EF 000216 and turn to tighten.
Junte las piezas 05 en la pieza 03, añade el herraje EF 000216 y gire para apretar.

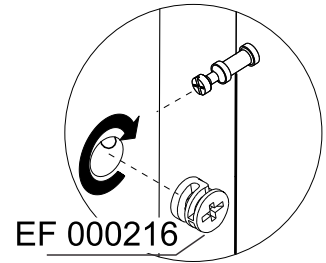
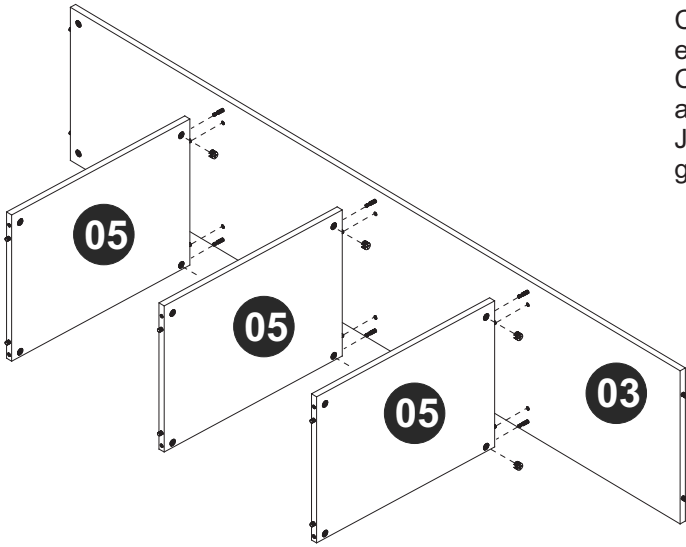

PASSO 6 / STEP 6 / PASO 6

Conecte a peça 04 à parte montada no passo anterior, insira a ferragem EF 000216 e gire para apertar.
Connect piece 04 to the part assembled into the previous step, insert hardware EF 000216 and turn to tighten.
Junte la pieza 04 a la parte armada en el paso anterior, añade el herraje EF 000216 y gire para apretar.

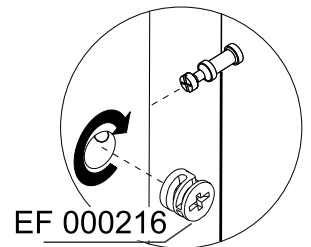
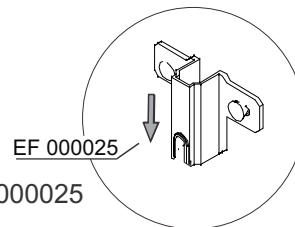
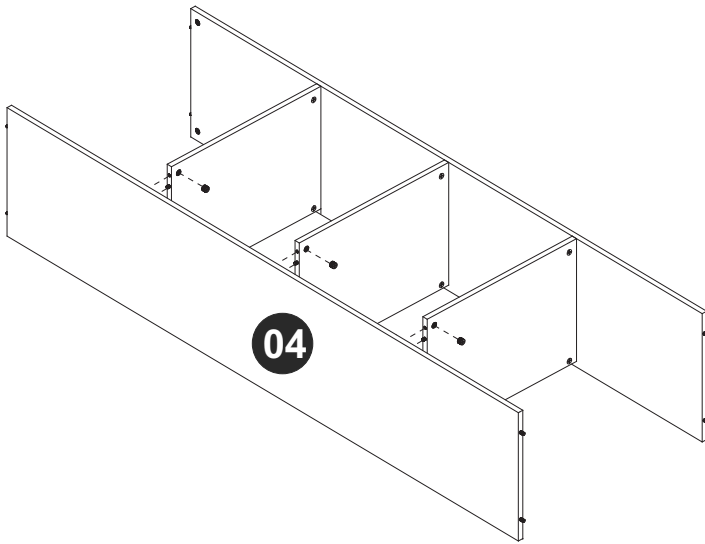

Por favor, observe a posição da ferragem EF 000025
Please, note hardware EF 000025 position.
Por favor, observe la posición del herraje EF000025.

PASSO 7 / STEP 7 / PASO 7

Conecte a peça 02 à parte montada no passo anterior, insira a ferragem EF 000216 e gire para apertar.
Connect piece 02 to the part assembled into the previous step, insert hardware EF 000216 and turn to tighten.
Junte la pieza 02 a la parte armada en el paso anterior, añade el herraje EF 000216 y gire para apretar.

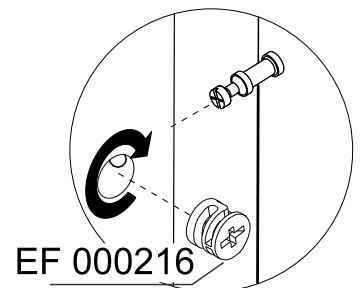
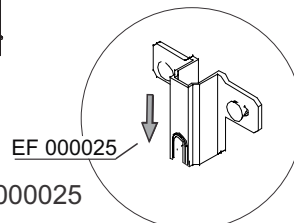
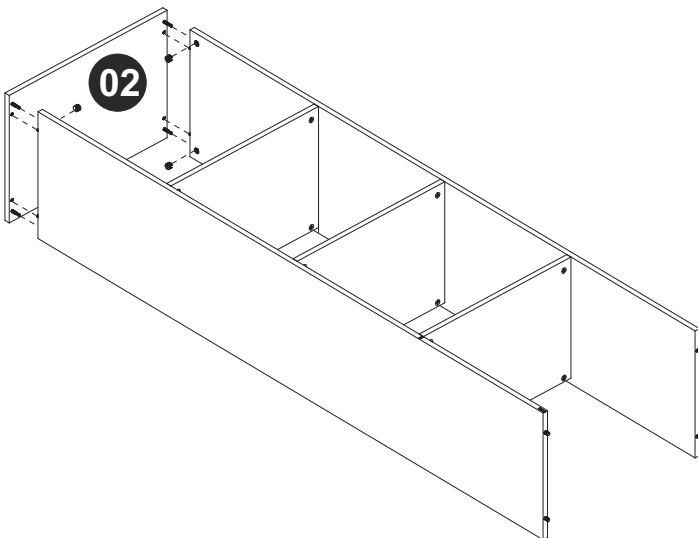

Por favor, observe a posição da ferragem EF 000025
Please, note hardware EF 000025 position.
Por favor, observe la posición del herraje EF000025.

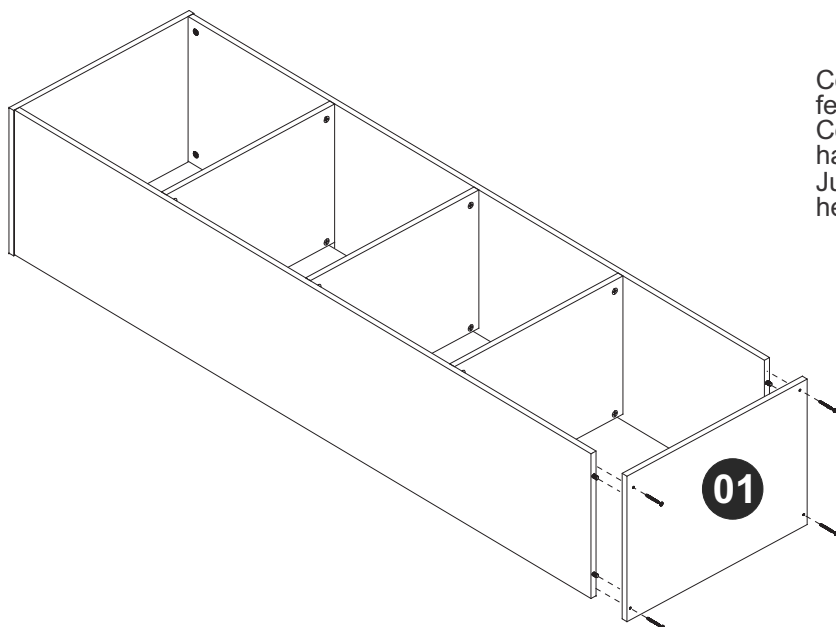

PASSO 8 / STEP 8 / PASO 8

Conecte a peça 01 ao móvel montado utilizando a ferragem EF 000132.
 Connect piece 01 at the assembled furniture using hardware EF 000132.
 Junte la pieza 01 al mueble armado utilizando el herraje EF 000132.

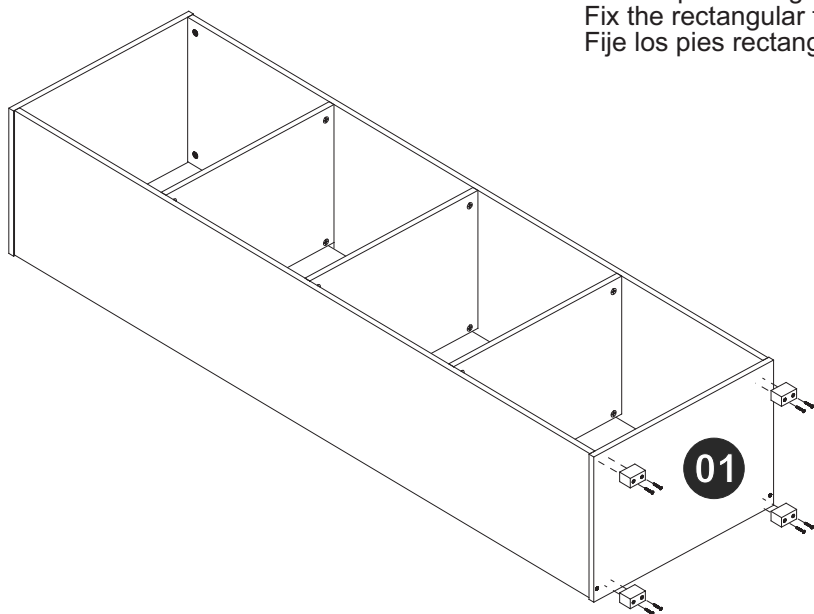
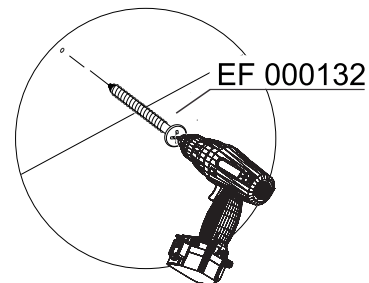

PASSO 9 / STEP 9 / PASO 9

Fixe os pés retangulares na peça 01 utilizando a ferragem EF 000381.
 Fix the rectangular feet at piece 01 using hardware EF 000381.
 Fije los pies rectangulares en la pieza 01 utilizando el herraje EF 000381.

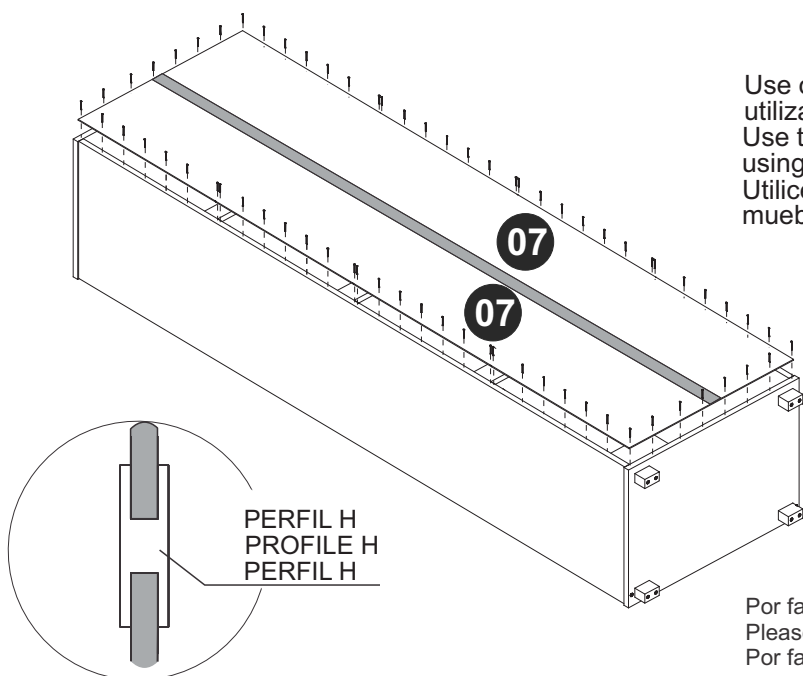
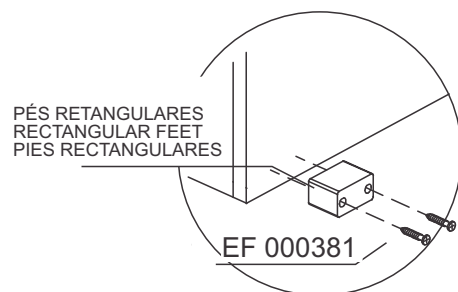

PASSO 10 / STEP 10 / PASO 10

Use o perfil H para unir as peças 07, fixe as peças 07 ao móvel utilizando a ferragem EF 000168.
 Use the profile H to join pieces 07, fix pieces 07 at the furniture using hardware EF 000168.
 Utilice el perfil H para juntar las piezas 07, fije las piezas 07 al mueble utilizando el herraje EF 000168.

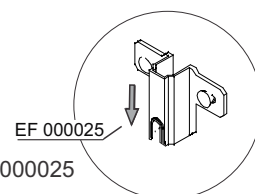
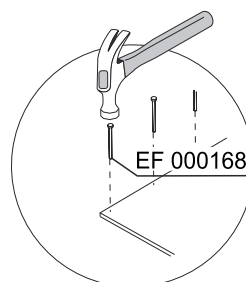

Por favor, observe a posição da ferragem EF 000025
 Please, note hardware EF 000025 position.
 Por favor, observe la posición del herraje EF000025.

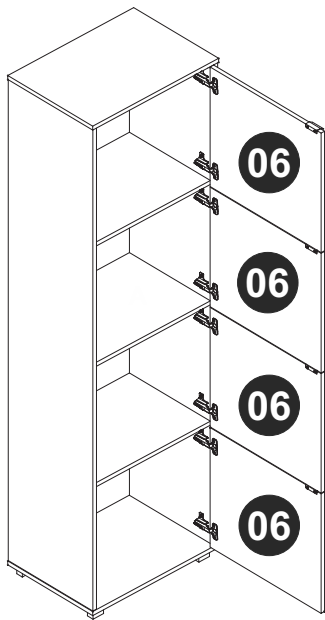

PASSO 11 / STEP 11 / PASO 11

Fixe as peças 06 ao móvel montado.
Fix piece 06 to the assembled furniture.
Fije la pieza 06 al mueble armado.

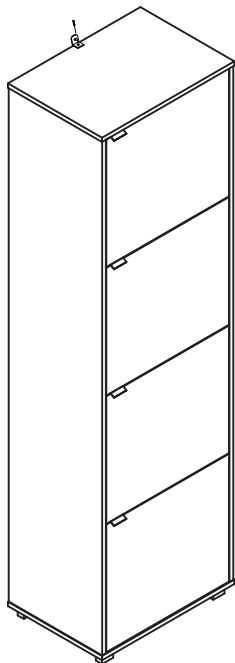
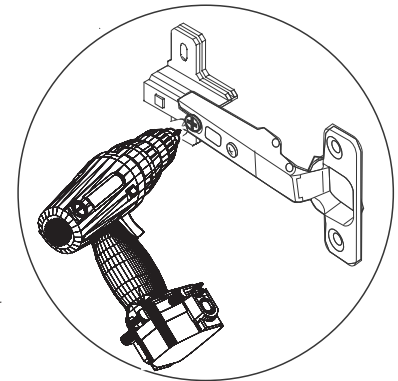

PASSO 12 / STEP 12 / PASO 12

Use o parafuso EF 000248 para fixar a ferragem EF 000529 ao móvel.
Use hardware EF 000248 to fix the hardware EF 000529 at the furniture.
Utilice el herraje EF 000248 para fijar el herraje EF000529 al mueble.

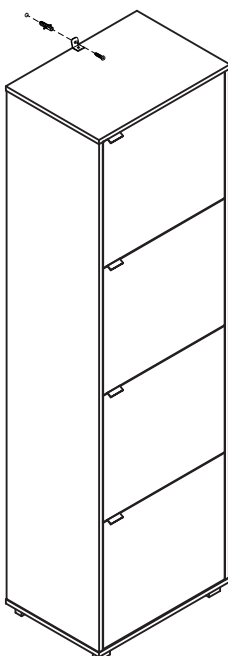
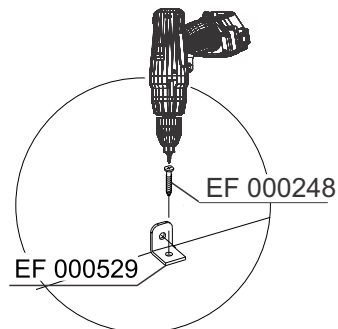

PASSO 13 / STEP 13 / PASO 13

Use as ferragens EF 000246 e EF 000016 para fixar o móvel na parede.
Use hardware EF 000246 and EF 000016 for fixing the furniture on the wall.
Utilice los herrajes EF000246 y EF000016 para fijar el mueble en la pared.

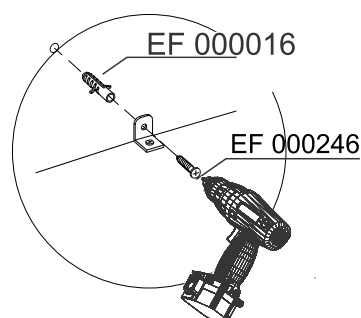

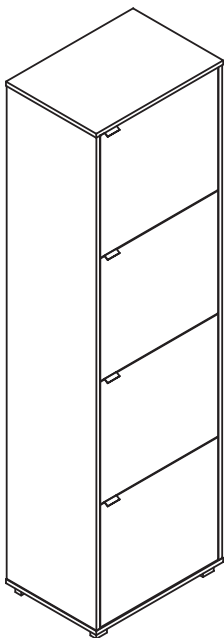

PASSO 14 / STEP 14 / PASO 14

Utilize o tapa furos para cobrir os parafusos aparentes.
Use the sticker to cover the apparent screws.
Utilice los tapa huecos para cubrir los tornillos aparentes.

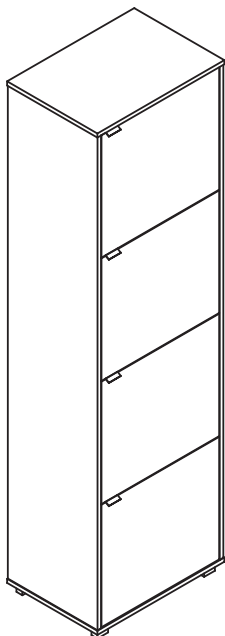
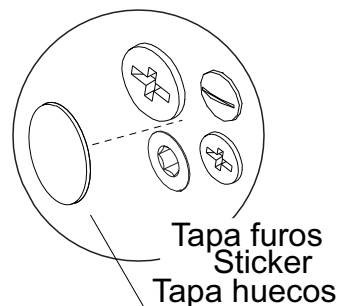

PASSO 15 / STEP 15 / PASO 15

Utilize o giz para dar o acabamento final ao produto.
Use the chalk to give the final finish on the product.
Utilize la tiza para dar el acabado final al producto.

